

DPW

専用交換ヘッド



交換可能



寸法 [mm]

標準品	QPH ラチェットヘッド	型式	角ドライブ	ラチェット歯数	S	H	G	D	L1	φD1	適用製品
	QPH10	6.35 (1/4)	72枚	25	17.5	8	16	45	10	10	DPW10
	QPH25	9.53 (3/8)		32	25.5	12	19	50	12	12	DPW25
	QPH50			39	33	16	26	65	15	15	DPW50S/DPW50
	QPH100	12.7 (1/2)		54	43	20	30	100	22	22	DPW100
	QPH200		68	49.5	20	41	125	30	30	DPW150/DPW200	
	QCH400	19.05 (3/4)	24枚	76	58	27	45	130	34	34	DPW300/DPW400
	QCH600			54	43	20	30	100	22	22	DPW600
	QCH1000			76	58	27	45	130	34	34	DPW850

寸法 [mm]

受注生産品	SPH スパナヘッド	型式	口幅W	S	T	L1	適用製品
<p>【型式】 SPH □□ - □□ SCH □□ - □□ 口幅W</p> <p>Fig1</p> <p>Fig2</p>	SPH10	5.5	16	4.5	45	DPW10	
		6	16				
		7	16				
		8	16				
		9	18				
		10	20				
		11	22				
		12	24				
		13	26				
		14	28				
	16	32					
	17	34					
	18	36					
	19	38					
	21	42					
	22	44					
	23	46					
	24	48					
	26	52					
	27	60					
	29	58					
30	60						
32	72						
34	78						
36	72						
38	76						
41	82						
46	92						
50	100						

寸法 [mm]

型式	口幅W	S	T	L1	適用製品
SPH200	17	34	10	80	DPW150 DPW200
	18	36			
	19	38			
	21	44			
	22	48			
	24	50			
	27	56			
	30	62			
	32	66			
	36	74			
41	84				
SCH400	17	34	12	100	DPW300 DPW400
	18	36.5			
	19	38.5			
	21	42			
	22	44			
	23	46			
	24	48			
	26	52			
	27	60			
	29	58			
	30	60			
	32	72			
	34	78			
	36	72			
38	76				
41	82				
46	92				
50	100				

※記載のない特注サイズはお問い合わせください。

DPW

専用交換ヘッド



寸法[mm]

寸法[mm]

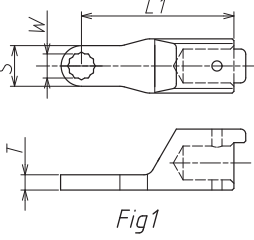
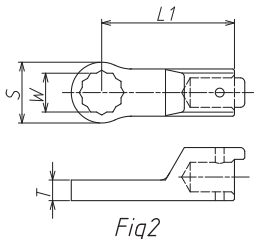
受注 生産品	RPH メガネヘッド	型式	口幅W	S	T	L1	適用製品
 <p>【型式】 RPH □□ - □□ RCH □□ - □□ 口幅W</p>  <p>Fig1</p>  <p>Fig2</p>	RPH10	6	9.5	4.5	45	DPW10	
		7	11				
		8	12.6				
		9	14.2				
		10	15.8				
		11	17.4				
		12	18.9				
		13	20.5				
		14	22.1				
		17	26.8				
		19	30				
		22	34.7				
	RPH25	6	9.5	4.5	50	DPW25	
		7	11				
		8	12.6				
		9	14.2				
		10	15.8				
		11	17.4				
		12	18.9				
		13	20.5				
		14	22.1				
		17	26.8				
19		30					
22		34.7					
RPH50	8	12.6	7	55	DPW50S DPW50		
	10	15.8					
	11	17.4					
	12	18.9					
	13	20.5					
	14	22.1					
	17	26.8					
	19	30					
	22	34.7					
	24	37.9					
	27	42.6					
	RPH100	12	18.9			8	65
13		20.5					
14		22.1					
17		26.8					
19		30					
22		34.7					
24		37.9					
27		42.6					
30		47.3					
32		50.5					

型式	口幅W	S	T	L1	適用製品
RPH200	17	26.8	10	80	DPW150 DPW200
	19	30			
	22	34.7			
	24	37.9			
	27	42.6	12		
	30	47.3			
	32	50.5			
	36	56.8	15		
	41	64.7			
	46	72.6			
RCH400	17	26.8	12	100	DPW300 DPW400
	19	30			
	22	34.7			
	24	37.9			
	27	42.6			
	30	47.3			
	32	50.5	15		
	34	53.6			
	36	56.8			
	41	64.7			
46	72.6	17			
50	78.9				

※記載のない特注サイズはお問い合わせください。

寸法[mm]

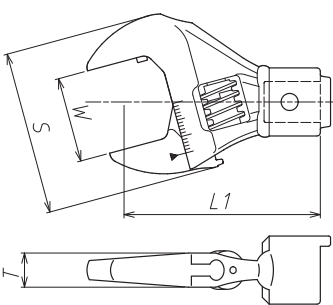
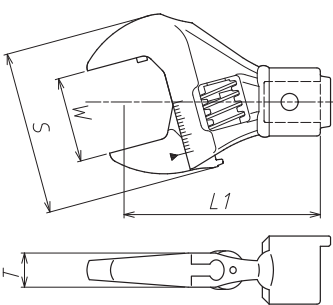
受注 生産品	HPY モンキヘッド	型式	口幅W	S	T	L1	適用製品
 		HPY20-10	0~20	46	10	50	DPW25
		HPY26-12	10~26	48	10	55	DPW50S/DPW50
		HPY30-15	10~30	58	12	65	DPW100
		HPY38-18	17~38	66	12.5	80	DPW150/DPW200

※モンキヘッドは4種類以外の取り扱いはございません。



株式会社 アドレック

〒959-1327 新潟県加茂市千刈1丁目1番12号
TEL.0256-52-1160 FAX.0256-52-1146 E-mail:info@adrec-jp.com
<https://www.adrec-jp.com>

